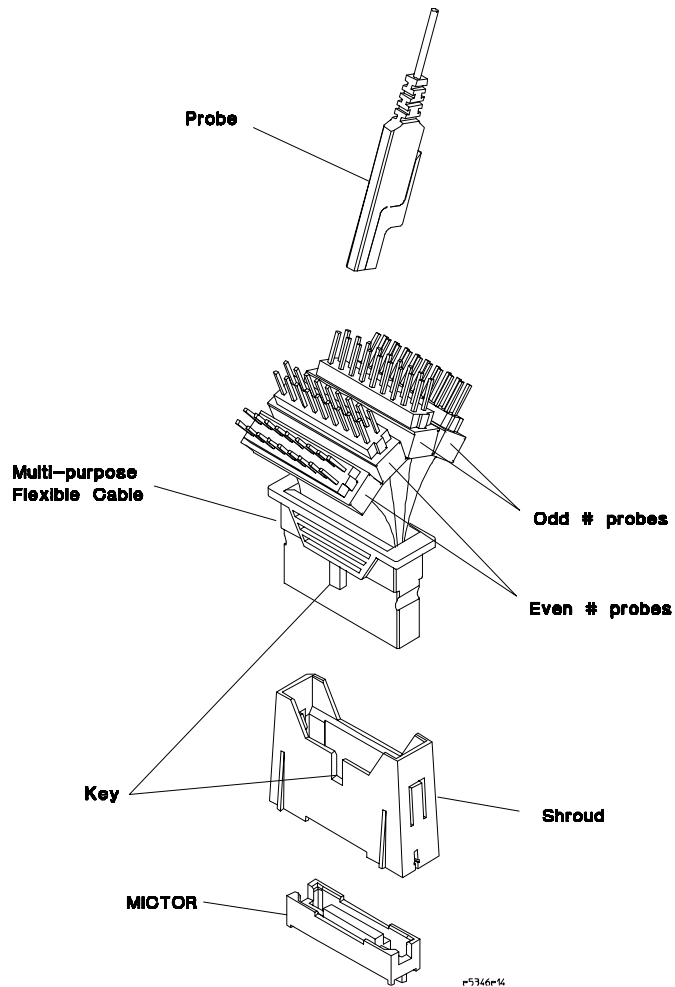

Agilent Technologies

E5346-60002

38-pin Adapter

Installation Note

The Agilent Technologies E5346-60002 High-Speed MICTOR Adapter provides a convenient way to connect two Agilent Technologies logic analyzer probe cables to an AMP MICTOR connector in your target system.



Installation

- 1 Attach the MICTOR connector(s) to the target system.**
Use AMP part number 2-767004-2 38-pin surface mount receptacles.
- 2 Align pin 1 of the MICTOR connector and pin 1 of the support shroud.**
- 3 Attach the support shroud around the MICTOR connector.**
Use Agilent Part Number E5346-44701 support shrouds.
- 4 Connect the high-speed adapter to the MICTOR connector.**
Tabs on the support shroud lock the multi-purpose flexible cable into the MICTOR connector to provide dependable connection and prevent it from inadvertently being disconnected. They also protect the flexible end of the cable from being bent and damaged.

CAUTION

Avoid damage to the MICTOR connector. Remove the flexible cable by pulling it straight out. Do not rock it back and forth to remove.

- 5 Use general-purpose probes to connect to the logic analyzer.**

Target Layout

Use the the following illustrations to plan and layout your target system.

See also

Refer to Agilent publication number 5962-8620E *Minimizing Intrusion Effects when Probing with a Logic Analyzer* for help on the terminations.

Board pad details of MICTOR connector

Notice the holes for mounting the support shrouds in the following illustration. They are off center to allow 0.40 in. (1.02 mm) centers. This helps orient the shroud in the correct position with pin 1 of the MICTOR.

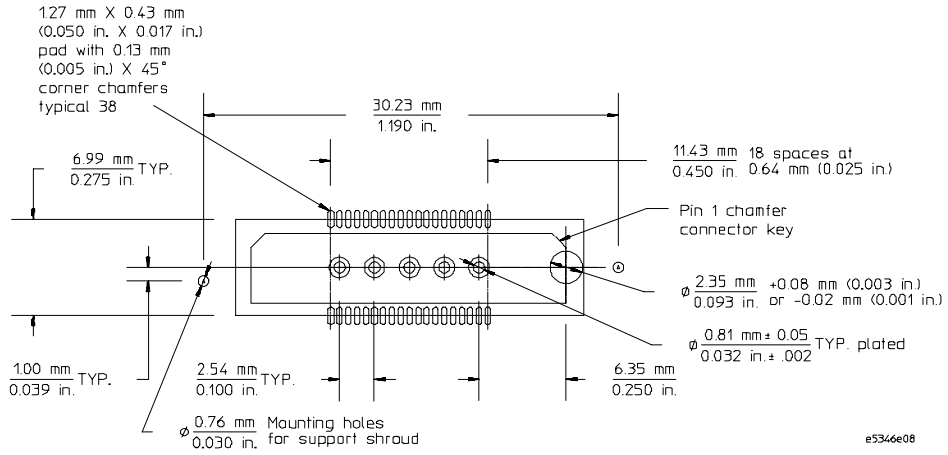

MICTOR connector dimensions

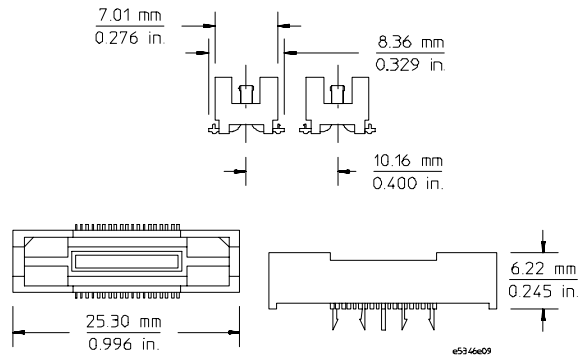

Distance from MICTOR to Target IC

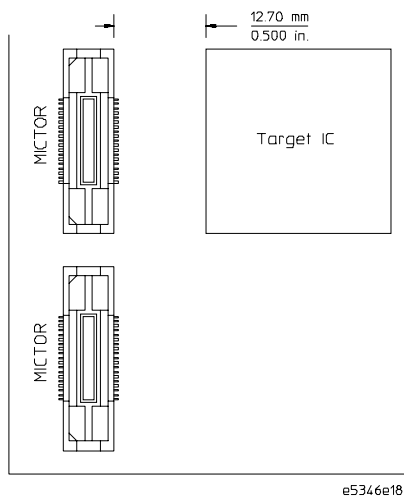

Support shroud dimensions

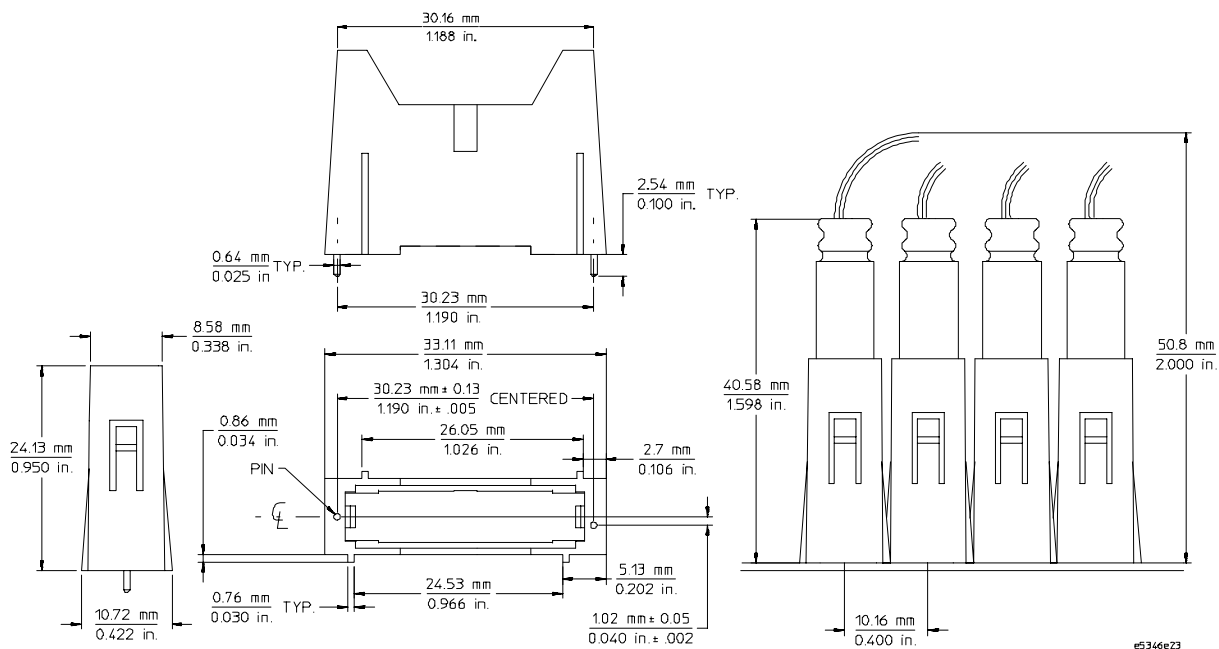

Multi-purpose flexible cable dimensions

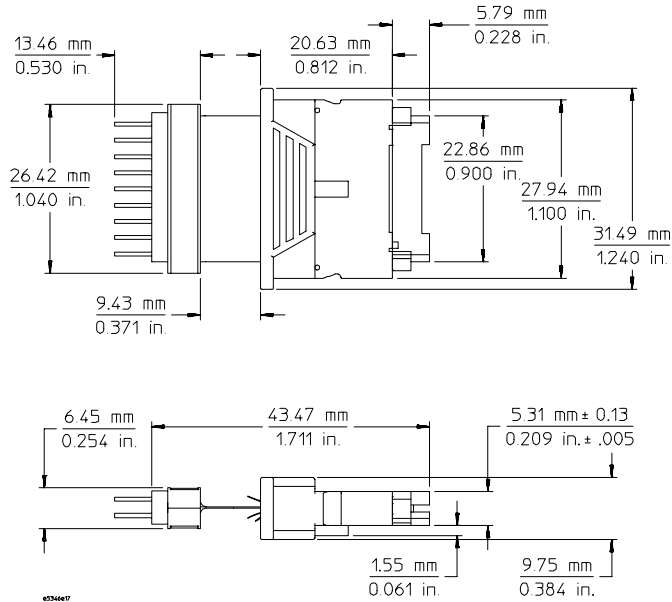

Pin out information

The following illustration is a top view of the surface mount receptacle. Turn the page for more pin out information.

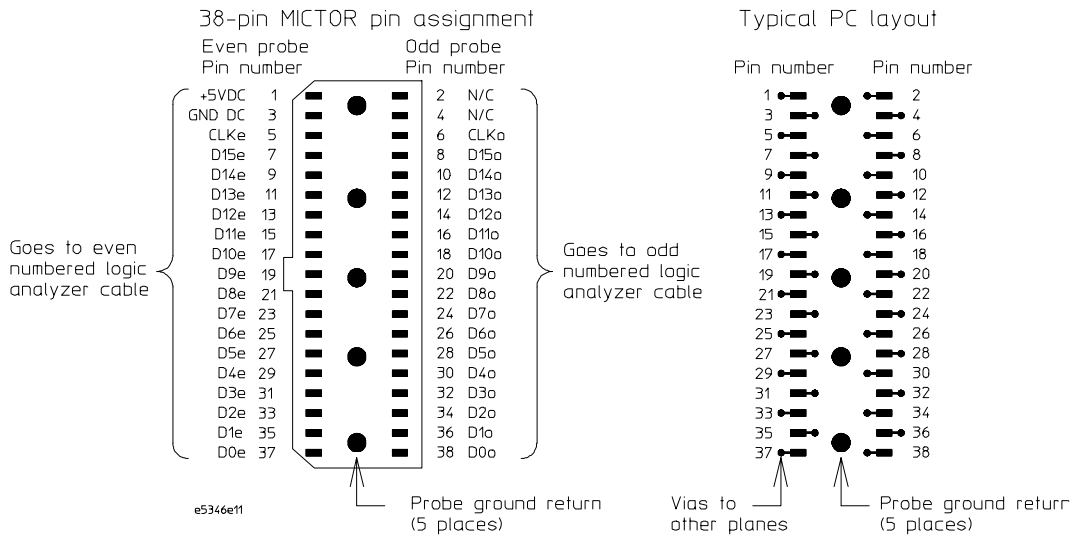

Pin 1 and pin 3 These pins are +5 volt and DC return for +5 volt supply. You can use 800 ma per probe up to a total of 10 amps for 20 probes. The logic analyzer supplies the power.

Pins 5, 7, ... 35, 37 These pins are even numbered logic probe inputs. CLKe is clock probe input used in state analysis. D15e to D0e on the even side are probe data inputs.

Pin 2 and pin 4 Do not connect pins. They are SCL and SDA used by the Agilent Technologies logic analyzer with an emulator or analysis probe (preprocessor) to program or read target information.

Pins 6, 8, ... 36, 38 These pins are odd numbered logic probe inputs. CLKo is clock probe input used in state analysis. D15o to D0o on the odd side are probe data inputs.

Grounds There are five thru-hole connections that are the ground returns for the 32 data and 2 clk probe inputs. This connection should be made to the target's digital ground plane as near to the target as possible.

All data and clock inputs are single endedly compared against a threshold that is determined by the logic analyzer family being probed. It can be ECL, TTL, or variable.

Schematic of multi-purpose flexible cable

The following illustrations show you the spice load model for the multi-purpose flexible cable and the pin locations.

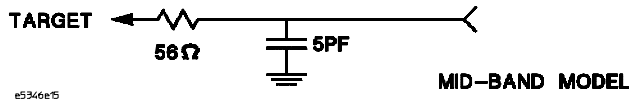
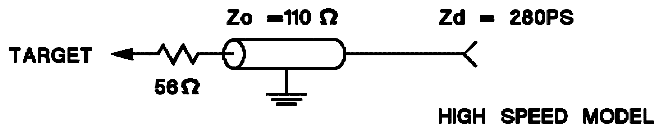

e5346e5

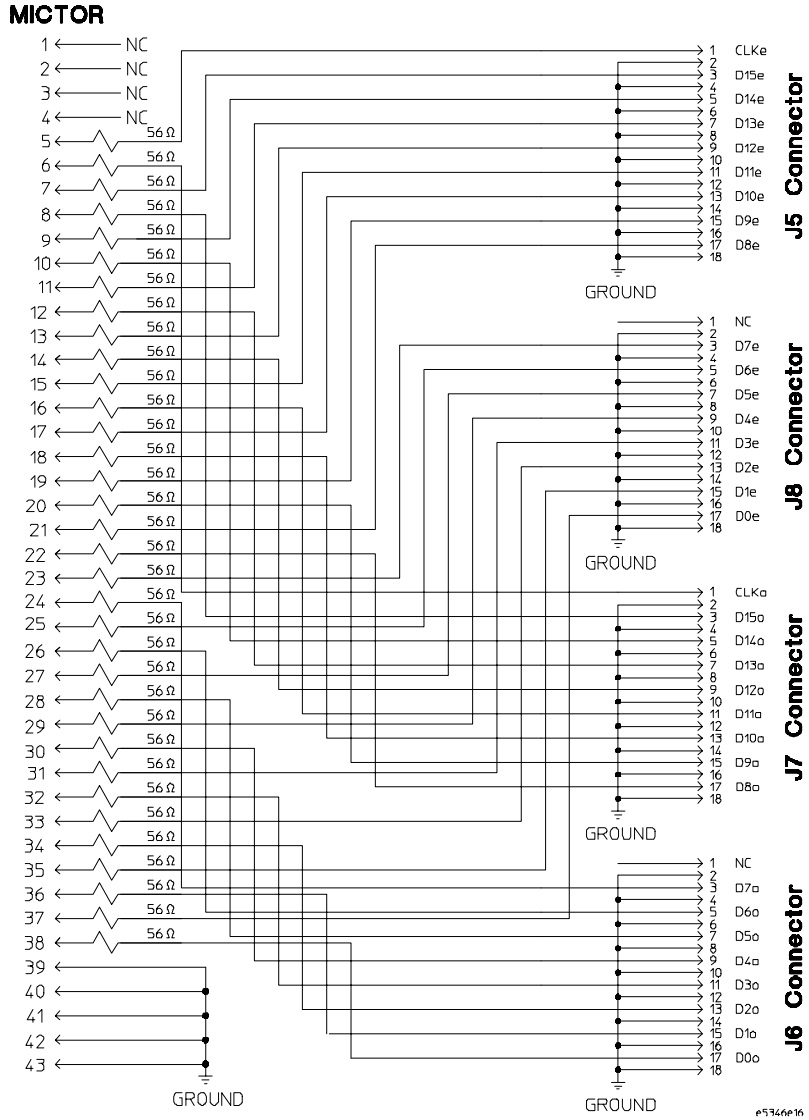

Cleaning the probe

Clean the probe using a soft cloth that has been moistened in a mixture of mild detergent and water.



Agilent Part Number E5346-92015
Printed June 2001